

OMER

www.omerlift.com

O.ME.R. S.p.a.
Via G. Galilei, 20
30035 Mirano (VE) ITALY
Tel. +39 041 570 0303
Fax +39 041 570 0273

info@omerlift.com



MINI 26 - 28 L

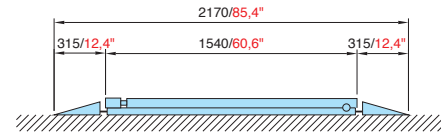
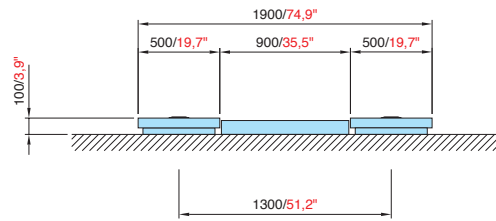
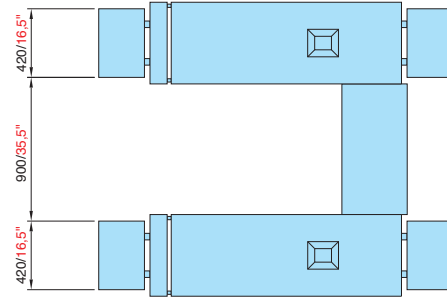
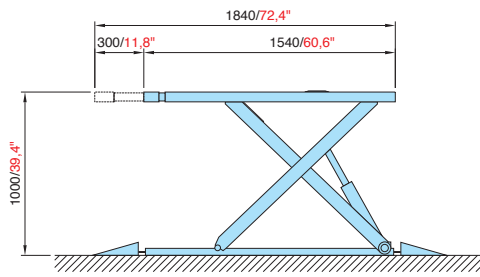

INCASSATO - FLUSH MOUNT - EINBAUMODELL - ENCASTRÉ - EMPOTRADO

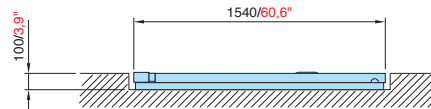
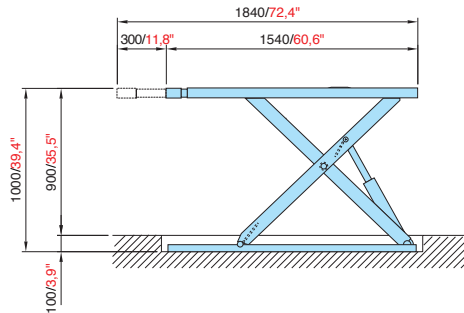

MM / KG INCH / LBS	Capacità Capacity Tragkraft Capacité Capacidad	Alimentazione - Feed - Versorgung - Alimentation - Alimentación		Pressione olio Oil pressure Betriebsdruck Pression d'huile Presion aceite	Quantità olio Oil capacity Hydraulikölmenge Reservoir d'huile Cant. aceite	Peso Gross Weight Gesamtgewicht Poids Peso	Tempo di salita Lifting time Hubzeit Temps de levée Tiempo de subida
		Elektrica - Electric Elektrische - Electrique Electrica	Pneumatica - Air operated Pneumatik - Pneumatique Neumatica				
MINI 26 L	2600 kg 5700 lbs	230-400V/3/50 Hz 1,5 KW	8÷10 Bar	260 Bar	10 l.	600 kg 1320 lbs	20 s
MINI 28 L	2800 kg 6200 lbs	230-400V/3/50 Hz 1,5 KW	8÷10 Bar	280 Bar	10 l.	600 kg 1320 lbs	20 s