

OMER

V E H I C L E L I F T S





Mini 28 LX



 Pedanina idraulica libera al centro con portata di 2800 Kg. Dotata di lamiera bugnata antiscivolo e di tutti i sistemi di sicurezza secondo le nuove Normative Europee. Nonostante i ridotti ingombri e dimensioni, è in grado di sollevare ogni tipo di autovettura grazie alla robustezza e alle prolunghe estraibili. La barra di torsione garantisce complanarità tra le corsie e affidabilità nel tempo.

 Hydraulic low-raise lift of 2800 kg. (6200 lbs) capacity. Anti-skid surface with diamond plate on the platforms and fitted with all safety systems according to the new European Regulations. Even with its reduced dimensions, it is able to lift all types of vehicles thanks to its strenght and to the extensions. The torsion bar ensures the perfect level between the platforms and reliability in terms of time.

 Hydraulische Hebebühne mit 2 Fahrbahnen und Tragfähigkeit 2800 Kg. Sie verfügt über Riffelblech und alle die Sicherheitssysteme gemäß der neuen Europäischen Regelungen. Trotz ihrer zeitsparrenden Maßen erlauben die herausziehbaren Verlängerungen und die Kraft dieser Hebebühne alle die Fahrzeugen aufzuheben. Der Torsionsstab leistet eine Sicherheit der Funktionsweise in der Zeit und des Gleichlaufes der Fahrbahnen.

 Pont élévateur hydraulique avec deux chemins de roulement et capacité de 2800 Kg. Le pont est équipé avec tôles antidérapantes et avec toutes les systèmes de sécurité selon les nouvelles Réglementations Européennes. Malgré les mesures réduites qui offrent le minimum d'encombrement, la puissance et les prolongements des chemins de roulement permettent de élever toutes les véhicules. La barre de torsion assure un parfait nivellement entre les chemins de roulement et fiabilité dans le temps.

 Puente elevador hidráulico con dos plataformas y con capacidad de 2800 Kg equipada de placa antideslizante y de todas las sistemas de seguridades conforme las nuevas Leyes Europeas. A pesar de las dimensiones reducidas, la robustez y las prolongaciones de las plataformas permiten de elevar todas los vehículos. La barra de torsión garantiza el perfecto paralelismo entre las plataformas y la fiabilidad del puente en el tiempo.

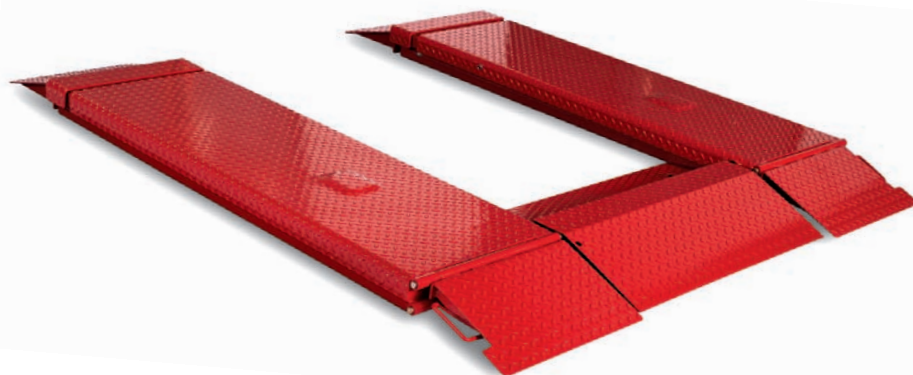

MM / KG INCH / LBS	Capacità Capacity Tragkraft Capacité Capacidad	Alimentazione - Feed - Versorgung - Alimentation - Alimentacion		Pressione olio Oil pressure Betriebsdruck Pression d'huile Presion aceite	Quantità olio Oil capacity Hydraulikölmenge Reservoir d'huile Cant. aceite	Peso Gross Weight Gesamtgewicht Poids Peso	Tempo di salita Lifting time Hubzeit Temps de levée Tiempo de subida
		Elettrica - Electric Elektrische - Electric Electrica	Pneumatica - Air operated Pneumatik - Pneumatic Neumatica				
MINI 28 LX	2800 kg 6200 lbs	230-400V/3/50 Hz 1,5 KW	8÷10 Bar	280 Bar	10 l.	600 kg 1320 lbs	20 s

MINI 28 LX

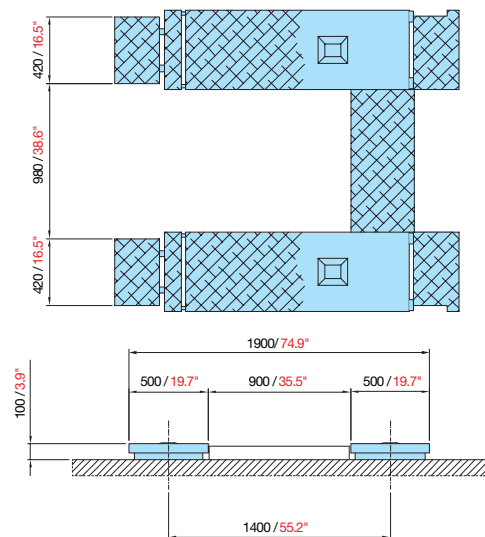
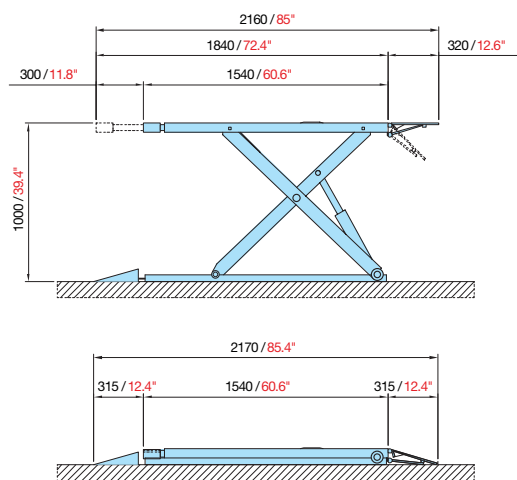

INCASSATO - FLUSH MOUNT - EINBAUMODELL - ENCASTRÉ - EMPOTRADO

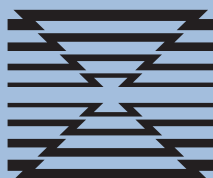
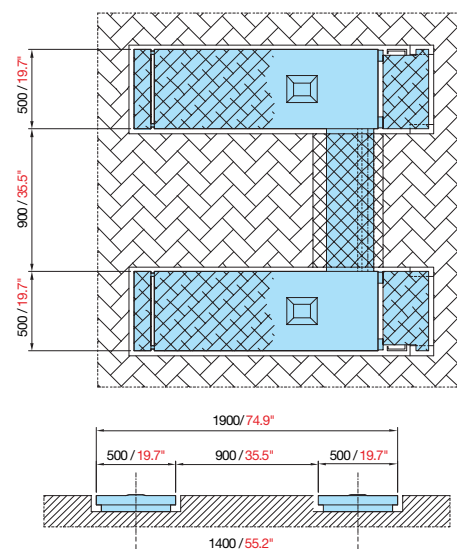
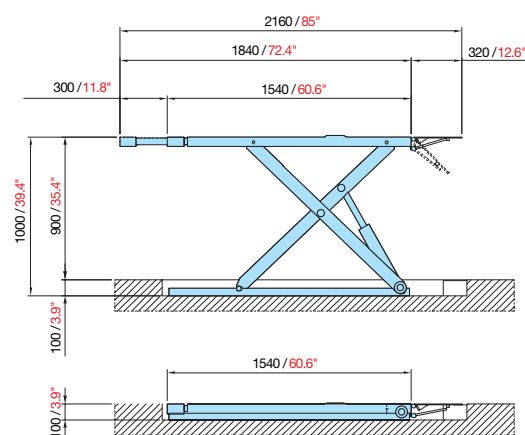

OMER

O.M.E.R. Spa Via G. Galilei, 20
30035 Mirano Venezia ITALY
Tel. +39 041 5700303
Fax +39 041 5700273
E-mail: info@omerlift.com
www.omerlift.com